



LASE 1000T Black-Line

Laser-Distance measuring by
"triangulation" technology



General characteristics:

- Contactless distance measuring
- Measuring area up to 700mm
- Ranges up to 1100mm
- Highest accuracy in the μm -area
- High measuring rate (up to 10 kHz)
- Ethernet interface optional
- Synchronized thickness measuring with 2 sensors
- Digital, analog and ethernet interfaces
- Suitable for operating off almost all surfaces
- Rugged construction, IP65
- Simple installation in each installation position
- Median filter
- Optical filtering of ambient light
- Closed-loop control of light intensity

Short description:

The distance sensors in the LASE 1000T series are optical measuring instruments that work according to the triangulation principle. This technique ensures highest accuracies within μm the range.

These sensors are typically used for the contactless distance and thickness/width measurement. The sensor produces thereby a visible laser point on an object. The relative position of this laser point is evaluated by a high resolution CCD line camera. From the position of this point along the CCD line, the distance is computed to the object.

The BlackLine Series, the procedure permits an accuracy of up to 0,0008mm depending its measuring range. By the Black-Line, the range on natural surfaces amounts to max. 1100 mm. The sensors incorporate automatic regulation of the light intensity and thereby provide unsurpassed measuring characteristics.

The LASE 1000T Sensors area a compact unit. The optical elements are integrated with the electronic components in a durable steel housing. The sensors contain no mobile parts and are appropriate for the work in the heavy industrial environment!

The LASE 1000T GreenLine Series offer larger measuring ranges with similar accuracies!

The complete LASE 1000T Series is used, where the precision demands better than 1 mm, e.g. by thickness measurements or quality controls:

- Measurement of length, width, height, level and situation of objects and environments
- Positioning of machine parts
- Control of qualities by paper, steel or aluminum coils
- Measurement of slab width and thickness
- Measuring of liquid level and solid materials
- Position of hot objects in furnaces
- Measurement and regulation of slack

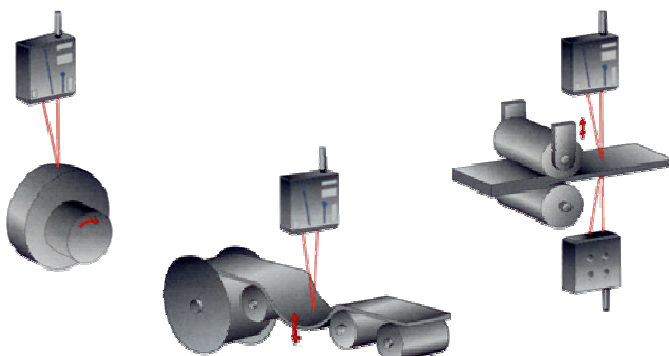

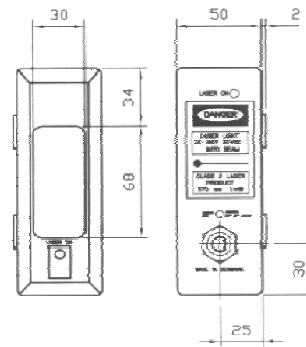
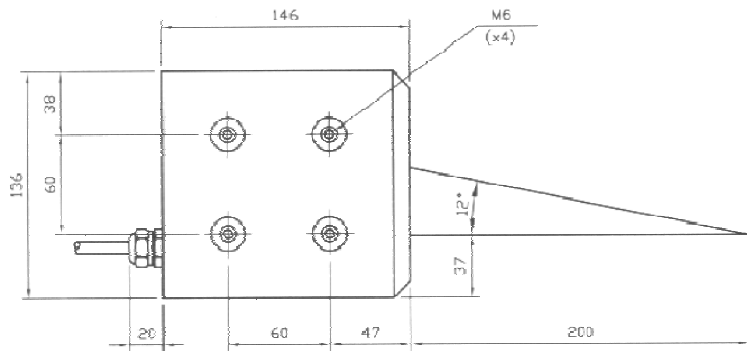

Technical Data LASE 1000T Black-Line Series

Model	LASE 1000T-20.5	LASE 1000T-115	LASE 1000T-150	LASE 1000T-200	LASE 1000T-250	LASE 1000T-450	LASE 1000T-750
Measuring range	16-25 mm	100-130 mm	100-200 mm	100-300 mm	100-400 mm	200-700 mm	400-1100 mm
Center distance	20,5 mm	115 mm	150 mm	200 mm	250 mm	450 mm	750 mm
Resolution *)	0,0008mm**	0,002mm	0,01mm**	0,05mm	0,08mm	0,1mm	0,5mm
Linearity *)	± 0,0045mm	± 0,03mm	± 0,05mm	± 0,1mm	± 0,2mm	± 0,3mm	± 0,7mm
Reproducibility *)	± 0,0008mm**	± 0,002mm	± 0,01mm**	± 0,05mm	± 0,08mm	± 0,1mm	± 0,5mm
Size of light spot	∅ 0,1 mm	∅ 1 mm	∅ 1 mm	∅ 2 mm	∅ 2 mm	∅ 2 mm	∅ 4 mm
Updating frequency	2000/1000 Hz						
Temperature deviation	± 0,03 % of FS/°C						
Light source	Visible Laser (670 nm)						
Laser protection class	IEC 2						
Interfaces: digital analog	Standard RS 232- optional RS422 – optional Ethernet 4-20mA or 1-9 VDC / 14 Bit						
Supply voltage	24 VDC ± 10 %						
Power consumption	Max. 4,5 W						
Operating temperature	0 bis +45 °C						
Degree of protection	IEC IP 65						
Dimensions in mm	136x138x50						136 x 146 x 50
Weight	1600 g						

*) Resolution, Reproducibility and Linearity valid for static measurement on white paper. Slight tolerances are possible on other surfaces.
FS: Full Scale

**) Details valid for digital output

Scope of delivery LASE 1000T: Special models:

- Sensor, Operation manual, Configuration- und Visualisation software
- All models are available as **HT-Versions** and **VHT-Versions** as well (for measurements on hot surfaces up to 1000 and 1500°C) - The standard version is useable only for a surface temperature of approx. 450 °C
- All models are available with 5-Select-Option (5 kHz)
- All models are available with 10-Select-Option (10 kHz)
- All models are available with **RS-422** interface (series by 5 and 10 kHz)
- All models are available with an optional **Ethernet** interface. The Ethernet interface can be used for distance measurement only, not for an internal thickness measurement.
- All models are available with laserclass **3R** and **3B**
- (series by 10 kHz and all VHT-devices)

Accessories (optional):

- Cool- and protection housing **ODS Kü01**



LASE
Industrielle Lasertechnik GmbH

CONTACT



LASE GmbH Industrielle Lasertechnik
Am Schornacker 59
D-46485 Wesel
Tel.: 0281 / 95990-0
Fax: 0281 / 95990-111
E-Mail: info@lase.de
Internet: www.lase.de